

WWW.JETINNOMACHINE.COM  
WWW.JETINNOVENDING.COM

**JETINO**<sup>®</sup>  
INSPIRE LIFE BETTER



Guangzhou Jetinno Intelligent Equipment Co., Ltd

Address: 4F, No. 2, Ruitai Road, Huangpu District, Guangzhou, China

Email: [inquiry@jetinno.com](mailto:inquiry@jetinno.com)

# PRODUCT CATALOG



Founded in 2013, JETINNO specializes in the research, design, and manufacturing of fully automatic coffee machines. We are committed to creating world-class coffee equipment with meticulous craftsmanship. Our fully automatic coffee machines are widely used in hotels, restaurants, cafés, convenience stores, vending, offices, and homes, ensuring that every cup of coffee delivers the perfect fusion of craftsmanship and technology.

Craft coffee machines with exquisite precision and unmatched quality. Provide a delightful coffee experience that leaves customers fully satisfied with every sip.



**17+ years**  
coffee machine  
expertise



**2**  
coffee machine  
factories



**70,000m<sup>2</sup>**  
R&D and manufacturing base  
(under construction)



**450+**  
employees



**80,000 sets**  
annual output



**80+**  
R&D engineers



**13**  
coffee machine labs



**170+**  
patents



**500+**  
global partners



**Sold in 96+**  
countries and regions

# MILESTONES

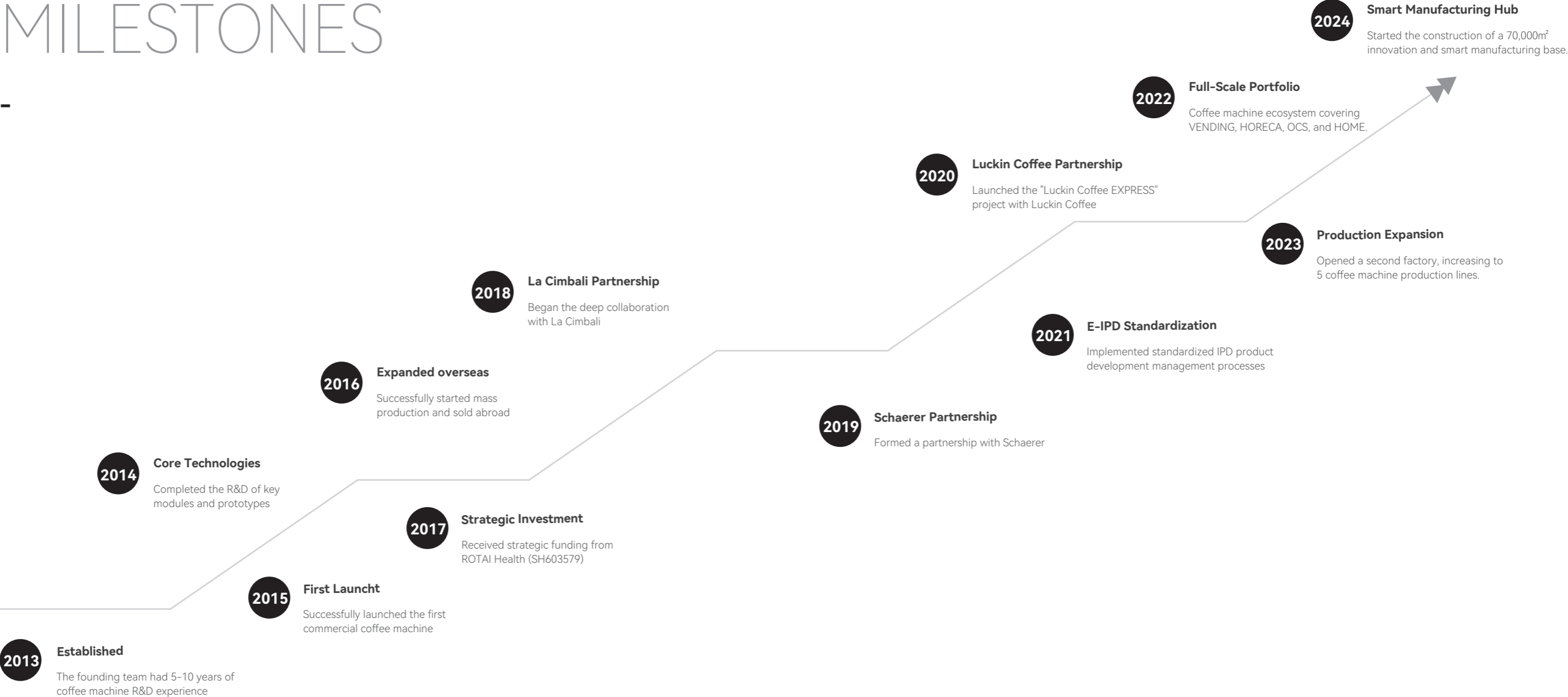

# MARKET

As of 2024, JETINNO's products are sold in over 96 countries and regions, earning the trust of more than 500 global clients. With a strong reputation for quality and service, the company has built a global presence through over 40 distributors and actively participates in more than 30 international industry exhibitions each year to enhance brand influence.



**96**  
countries and regions

**500+**  
global partners

**40+**  
global distributors

**30+**  
international exhibitions

## Overseas Partners

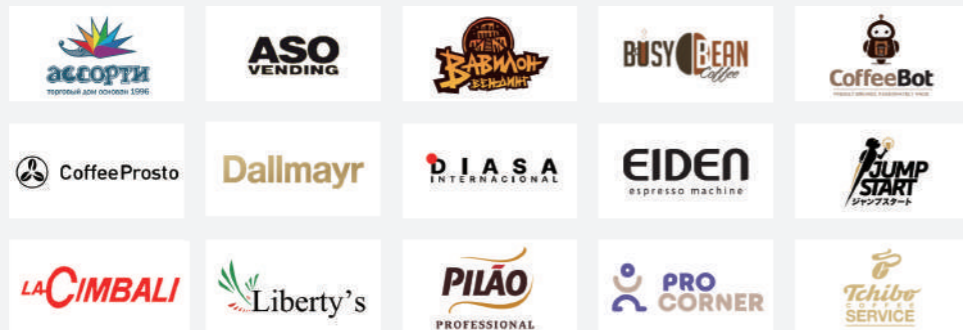

## Domestic Partners

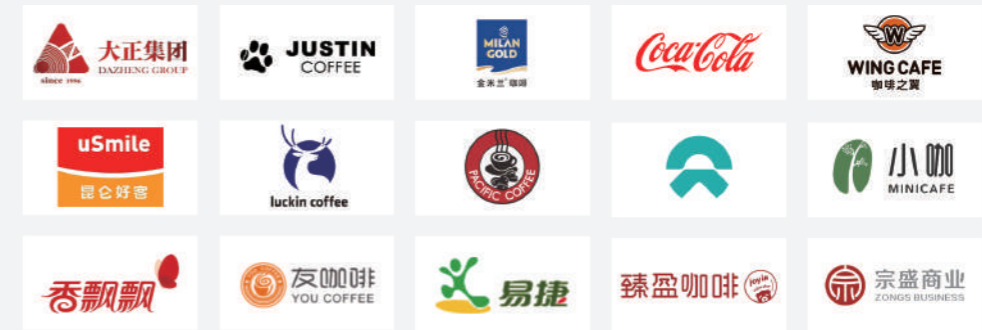

# SERVICE

Jetinno upholds the service principles of integrity, reliability, responsibility, and efficiency, embedding them into every aspect of our operations—from product design and manufacturing to sales and after-sales service. This commitment ensures prompt, professional support and enhances customer satisfaction.



## Spare Parts

Order with free essential spare parts  
Efficient logistics to ensure quick and reliable delivery worldwide.  
Online parts catalog and ordering system

## Training

Product Training: product features, functionalities, and applications.  
Operation Training: Hands-on guidance on product usage and best practices.  
Repairing Training: Advanced troubleshooting and repair techniques to minimize downtime.

## Technical Support

Video call troubleshooting to solve problems in real time.  
On-Site in-person assistance when necessary.  
Professional support team commanding multiple languages

# TECHNOLOGY

Fueled by innovation, JETINNO's R&D center drives technological advancement with 13 specialized coffee machine labs and cutting-edge testing equipment.

Certified by the Guangdong Provincial Engineering Technology Research Center and SGS Laboratories, our 80+ expert engineers have secured 170+ national patents, with products meeting CCC, CE, PSE, and KR certifications.

Grinding System  
High-precision 64mm special steel flat burrs for durability, adjustable grind size for uniform and fine coffee grounds.



## Grinding System

High-precision 64mm special steel flat burrs for durability, adjustable grind size for uniform and fine coffee grounds.



## Brewing System

PCT international patent with 9-bar reverse gravity extraction and pre-wetting for optimal flavor. Quick-disassembly (5s) for deep cleaning.



## Milk Frothing System

Real-time milk temperature monitoring with automatic milk tube cleaning. Intelligent milk level alerts for seamless operation.

**13**

R&D Labs(including those under construction)

**170+**

Coffee Machine Patents

**80+**

R&D Engineers



## I-JETINNO Platform

Cloud-based SaaS management software enabling DIY drink customization, QR payments, remote machine monitoring, and data analytics.



## Self-Cleaning System

Automated cleaning for water, coffee, mix, and milk components with scheduled cleaning for hygiene and stable operation.



## Automatic Cup & Lid System

Smart cup & lid dispensing with real-time monitoring and alerts for missing items. Supports 70/80/90mm paper cups/lids.



## Filter Brewer

Dual-purpose filter coffee & tea brewer with replaceable meshes. High-density filter holes prevent residue buildup, and quick disassembly ensures easy cleaning.

# TECHNOLOGY

JETINNO has independently developed core technologies for key commercial coffee machine components, forming a complete, self-sustained technology system.



## Grinding System

### PGH64 Grinder

Grinding speed: 2.0-3.8 g/s  
Motor lifespan: 125,000 cycles  
Burr lifespan: 500kg coffee beans

### SGH64 Grinder

Grinding speed: 2.0-3.0 g/s  
Motor lifespan: 37,500 cycles  
Burr lifespan: 400-500kg coffee beans



## Extraction System

### P14/20 Espresso Brewer

Premium brewing system  
14g/20g chamber options  
Lifespan: 80,000 cycles

### S14/20 Espresso Brewer

Direct powder drop for even distribution  
14g/20g chamber options  
Lifespan: 40,000 cycles



## Filter Brewer

### Filter Brewer

Brewing chamber: 6-14g capacity  
High-temperature extraction at 90°C  
Pre-wetting and spray brewing technology

## Milk Frothing System



### FM Hot & Cold Milk/Froth System

Italy Fluid-o-tech professional milk pump  
Produces hot/cold milk froth and milk  
Customizable froth dryness, wetness, and temperature



### FV Hot Milk Frothing System

Produces hot milk and hot milk froth  
Froth temperature: 60°C-70°C  
Adjustable milk temperature

## Mixing System



### Powder Canister

Smart calibration of powder dispensing  
Precise control of powder output  
No-residue design for powder dispensing



### Mixer

Customizable mixing speed for recipe needs  
20,000 rpm for fast powder dissolution  
Anti-clogging, powder tunnel dehumidification design

## Water System

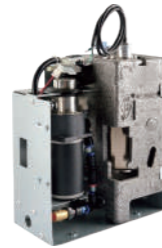

### Hot Water Module

700mL high-pressure stainless steel boiler  
2700W high-power continuous hot water  
Sensors for real-time temperature/pressure monitoring  
Modular design for easy disassembly and maintenance  
Components sourced from top global suppliers



### Ice Maker

Ice production:  $\geq 4\text{kg/h}$  (1.2g mineral block ice)  
Continuous ice output:  $\geq 15$  cups (180g/cup)  
1.5kg ice bucket storage  
Smart alerts for water shortage, full ice, over-cooling, and low ice  
UV sterilization ice-making water system design

## Automatic Cup & Lid System



### Automatic Cup Dispensing Module

Five-cup bin design for 150 double-layer cups (90mm/160oz)  
Smart cup dispensing function



### Automatic Lid Dispensing Module

Single-cup bin design for 180 injection-molded lids (90mm)  
Smart lid dispensing function



# TECHNOLOGY

## I-Jetinno SaaS Platform

I-Jetinno is an advanced SaaS-based coffee machine management platform that helps coffee business operators streamline operations, reduce downtime, and maximize revenue.



### Comprehensive Equipment Management

Real-time machine status monitoring, including component functionality, material levels, and error reports.  
Remote control of machine settings, including beverage recipes, screen advertisements, and operational parameters.

### Automated Fault Detection & Maintenance

Intelligent system alerts for machine malfunctions, material shortages, and performance issues.  
Supports remote diagnostics and troubleshooting, minimizing downtime and maintenance costs.

### Sales & Transaction Analytics

Provides detailed sales reports, revenue tracking, and transaction records.  
Supports multi-dimensional analysis to optimize pricing, promotions, and product offerings.

### Multi-Channel Payment Integration

Compatible with QR code payments, credit card transactions, and mobile payment solutions.  
Ensures secure and seamless transactions while generating real-time financial reports.

### Cloud-Based Beverage & Recipe Management

Centralized platform for customizing and distributing beverage recipes across multiple machines.  
Ensures consistent drink quality and quick adaptation to market trends.

### Multi-Level Business & User Management

Hierarchical merchant account system for managing multiple locations under a single account.  
Customizable access permissions for different roles, ensuring secure and structured operations.

# PRODUCTION

## Craftsmanship and Intelligence

A quality-driven production center rigorously enforces quality from inception, implements comprehensive testing protocols, strictly adheres to ISO quality management standards, ensuring consistently stable and efficient performance in every coffee machine.

**2**

Coffee Machine Factories

**5**

Fully Automatic Coffee Machine Production Lines

**70,000m<sup>2</sup>**

Intelligent Coffee Machine Manufacturing Base  
(Under Construction)

**200,000 Units**

Estimated Production Capacity



### 100% Component Control

Every supplier is rigorously evaluated, and all components undergo IQC inspection to ensure quality from the source.

### 100% Function Testing

Each machine undergoes a full functionality test to guarantee compliance with quality and safety standards.

### 100% Beverage Testing

Every cup is tested for concentration, temperature, weight, and dispensing time to meet company and industry standards.

### 100% Full Machine Inspection

Each unit is thoroughly checked before shipping, covering appearance, accessories, custom requirements, and labeling.

### Scheduled Reliability Testing

Regular sampling tests for temperature resistance, vibration, drop impact, beverage consistency, and safety to ensure product reliability.

# PRODUCTS



01

Home



02

OCS-FM

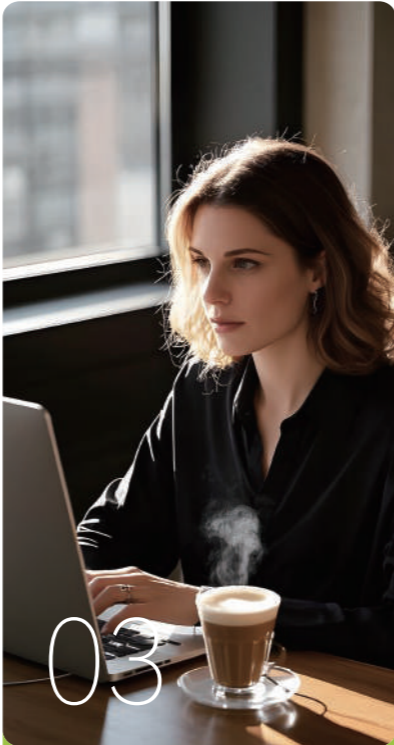

03

OCS-PM



04

Ho.Re.Ca



05

Vending



06

Coffee to Go

**Home**

**OCS-FM**

**OCS-PM**

**Ho.Re.Ca**

**Vending**

**Coffee to Go**

JL05



JL29B



JL22



JL36



JL28



JL510



JL06



JL30



JL23



JL32



JL40



JL560



JL08



JL31A



JL24



JL33



JL220



JL852



JL09



JL31B



JL18



JL35



JL300



JL10



JL26



JL500



JL15



JL50



JL550





Equipped with commercial-grade grinding and brewing system, ensuring premium coffee quality in every cup. Featuring a sleek design, smart controls, and user-friendly operation, it allows you to craft barista-quality coffee in your own house.



JL05

CCC CE CB

Daily Output:  
**10 cups**

Colors:



Optional Accessory:  
**Milk Tank**



**Commercial-Grade Grinding & Brewing**

Equipped with patented SGH64 commercial grinder and S14 espresso brewer, ensuring professional stability and authentic coffee flavor in every cup.



**Smart APP Control**

Allows remote ordering via mobile app, personalized coffee customization, and saving preferences for a tailor-made coffee experience.



**Adjustable Coffee Strength**

Manual knob for coffee strength adjustment to suit different taste preferences, ensuring every cup is perfectly tailored to your taste.

Model	Power	Dimensions	Net Weight	Grinder	Brewer	Heating	Pump	Milk System
<b>JL05A</b>	1600W	240(W)*360(H)*450(D)mm	9.5kg	SGH64 x 1	S14 x 1	Thermoblock x 1	Piston pump x 1	—
<b>JL05B</b>	1600W	240(W)*360(H)*450(D)mm	10kg	SGH64 x 1	S14 x 1	Thermoblock x 1	Piston pump x 1	Milk frother
<b>JL05C</b>	1600W	240(W)*360(H)*450(D)mm	10.5kg	SGH64 x 1	S14 x 1	Thermoblock x 1	Piston pump x 1	—

Steam Wand	Spout Height	Bean Hopper	Water Tank	Drip Tray	Waste Bin
—	80-140mm	200g x 1	1.6L	0.6L	10 cakes (8g)
—	80-140mm	200g x 1	1.6L	0.6L	10 cakes (8g)
1	80-140mm	200g x 1	1.6L	0.6L	10 cakes (8g)



JL06

CCC CE CB

Daily Output:  
**10 cups**

Colors:  
● ●

Optional Accessory:  
**Milk Tank**



**Innovative Design**

Crafted by Italian designers with a stylish and distinctive look. Features a curved menu interface for an intuitive and user-friendly experience.



**Cold Brew Coffee**

Fast cold brew technology delivers smooth, naturally sweet cold brew coffee in just 5 minutes, preserving the original flavor and aroma of the coffee.



**Detachable Brewer for Easy Cleaning**

Smartly designed brewing unit allows for quick disassembly and easy cleaning, ensuring a consistently hygienic machine interior.

Model	Power	Dimensions	Net Weight	Grinder	Brewer	Heating	Pump	Milk System
<b>JL06A</b>	1600W	240(W)*360(H)*450(D)mm	9.5kg	SGH64 x 1	S14 x 1	Thermoblock x 1	Piston pump x 1	—
<b>JL06B</b>	1600W	240(W)*360(H)*450(D)mm	10kg	SGH64 x 1	S14 x 1	Thermoblock x 1	Piston pump x 1	Milk frother
<b>JL06C</b>	1600W	240(W)*360(H)*450(D)mm	10.5kg	SGH64 x 1	S14 x 1	Thermoblock x 1	Piston pump x 1	—

Steam Wand	Spout Height	Bean Hopper	Water Tank	Drip Tray	Waste Bin
—	80-140mm	200g x 1	1.6L	0.6L	10 cakes (8g)
—	80-140mm	200g x 1	1.6L	0.6L	10 cakes (8g)
1	80-140mm	200g x 1	1.6L	0.6L	10 cakes (8g)



# JL15



Daily Output:  
**60 cups**

Colors:



Optional Accessory:

**Milk Tank / Fresh Milk Fridge**

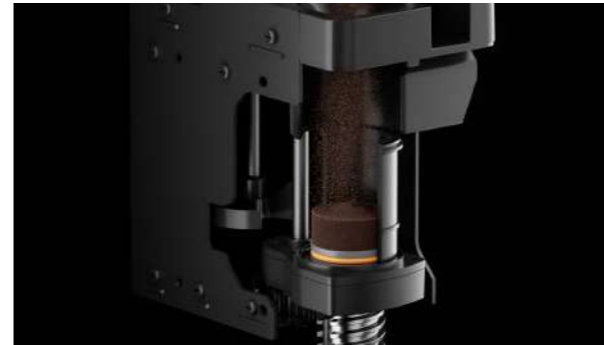

### Professional Coffee Extraction

Equipped with JETINNO's patented S14 brewer (optional S20), featuring high-pressure espresso extraction for precise control over the brewing process, ensuring consistent coffee quality in every cup.



### Beverage Customization

Advanced backend settings allow users to fully customize their drinks, offering endless customization possibilities to satisfy coffee enthusiasts' desire for exploration.



### Smart Auto-Cleaning

One-touch automatic cleaning for the brewer and fresh milk system, ensuring effortless maintenance and hygiene.

Model	Power	Dimensions	Net Weight	Grinder	Brewer	Heating	Pump	Milk System
<b>JL08</b>	1700W	300(W)*440(H)*490(D)mm	15kg	SGH64 x 1	S14x1/S20 (optional)	Thermoblock x 1	Piston pump x 1	—
<b>JL09</b>	1700W	300(W)*440(H)*490(D)mm	15kg	SGH64 x 1	S14x1/S20 (optional)	Thermoblock x 1	Piston pump x 1	—
<b>JL10</b>	1700W	300(W)*440(H)*490(D)mm	15kg	SGH64 x 1	S14x1/S20 (optional)	Thermoblock x 1	Piston pump x 1	Milk frother
<b>JL15</b>	1700W	300(W)*440(H)*490(D)mm	16kg	SGH64 x 1	S14x1/S20 (optional)	Thermoblock x 2	Piston pump x 1	Milk frother

Steam Wand	Drip Tray	Bean Hopper	Daily Output	Water Tank	Waste Bin
—	0.7L	500g x 1	30	2L, Opt. 8L	40 cakes (10g)
1	0.7L	500g x 1	30	2L, Opt. 8L	40 cakes (10g)
—	0.7L	500g x 1	30	2L, Opt. 8L	40 cakes (10g)
—	0.7L	500g x 1	60	2L, Opt. 8L	40 cakes (10g)





Combining high-efficiency grinding with professional espresso extraction, OCS-FM machines precisely unlocks the bold, aromatic flavors of coffee while delivering a smooth, well-rounded taste. The innovative fresh milk system creates smooth, velvety milk foam that blends perfectly with coffee for a creamy, indulgent experience. With intelligent auto-cleaning and detachable components, maintenance is more convenient and efficient.



# JL29B

CQC CE CB

Daily Output: **100 cups** Colors:



# JL30

CQC CE CB

Daily Output: **100 cups** Colors:   Optional Accessory: **Fresh Milk Fridge**



### Professional Espresso Extraction

Equipped with patented S14 brewer (optional S20), delivering high-pressure espresso extraction with rich crema, ensuring premium beverage quality for every cup.



### Quick-Release Cleaning for Hygiene Assurance

One-touch quick-release brewing unit for easy cleaning, keeping the machine interior consistently clean and hygienic.



### Smart Bean Shortage Detection

Intelligent bean shortage alerts to ensure timely refilling, optimizing operational efficiency.



Model	Power	Dimensions	Net Weight	Grinder	Brewer	Heating	Pump	Milk System
<b>JL29B</b>	1500W	300(W)*548(H)*490(D)mm	16kg	SGH64 x 1	S14x1/S20 (optional)	Thermoblock x 1	Piston pump x 1	—
<b>JL30</b>	1500W	300(W)*548(H)*490(D)mm	17kg	SGH64 x 1	S14x1/S20 (optional)	Thermoblock x 2	Piston pump x 1	Milk frother

Screen Type	Spout Height	Drip Tray	Bean Hopper	Water Tank	Waste Bin
7" touch screen	80-160mm	1L, direct drainage (optional)	1200g x 1	2L, Opt. 8L	50 cakes (10g), direct slagging off (optional)
7" touch screen	80-160mm	1L, direct drainage (optional)	1200g x 1	2L, Opt. 8L	50 cakes (10g), direct slagging off (optional)



# JL31A

CQC CE CB

Daily Output:  
100 cups

Colors:  
● ●

Optional Accessory:  
Fresh Milk Fridge



# JL31B

CQC CE CB

Daily Output:  
100 cups

Colors:  
● ●

Optional Accessory:  
Fresh Milk Fridge



### Dual Pump & Dual Boiler

High-efficiency dual pump and dual boiler design enables simultaneous coffee and milk preparation, improving beverage production speed and reducing wait times—perfect for handling peak hours with ease.



### Versatile Water Supply Options

Built-in 2L water tank (optional 8L), compatible with barreled water and direct tap water. Three flexible water supply options to suit different operational needs.



### Hot Water Spout

Equipped with a dedicated hot water spout for one-touch dispensing, ensuring convenience and efficiency.



Model	Power	Dimensions	Net Weight	Grinder	Brewer	Heating	Pump	Milk System
JL31A	2850W	300(W)*548(H)*490(D)mm	18kg	SGH64 x 1	S14x1/S20 (optional)	Thermoblock x 2	Piston pump x 2	Milk frother
JL31B	2850W	300(W)*548(H)*490(D)mm	19kg	SGH64 x 1	S14x1/S20 (optional)	Thermoblock x 2	Piston pump x 2	Milk frother

Screen Type	Hot Water Spout	Drip Tray	Bean Hopper	Water Tank	Waste Bin
7" touch screen	1	1L, direct drainage (optional)	1200g x 1	2L, Opt. 8L	50 cakes (10g), direct slugging off (optional)
10.1" touch screen	1	1L, direct drainage (optional)	1200g x 1	2L, Opt. 8L	50 cakes (10g), direct slugging off (optional)



A fully automatic freshly ground coffee machine equipped with professional grinding and extraction systems to ensure consistent, high-quality coffee in high-demand environments. Its multi-Mix canister design offers a variety of coffee flavors and instant beverage options.



JL22/23

CQC CE CB

Daily Output:  
**150 cups**

Colors:  
●

Optional Accessory:  
**Base cabinet**



**Advanced Brewing System**

Equipped with a high-performance P14 brewer (optional P20) and a 2700W storage boiler, ensuring stable 9-bar pressure and 92°C optimal extraction for consistently exceptional beverage quality.



**Compact Design**

Sleek and space-saving, designed to fit into limited spaces while seamlessly integrating into various commercial environments.



**10+ Beverage Options**

Multi-canister design enables the preparation of a wide range of drinks, including black coffee, milk-based coffee, and instant beverages, catering to diverse consumer preferences.

Model	Power	Dimensions	Net Weight	Grinder	Brewer	Heating	Pump
<b>JL22-ES4C</b>	2700W	400(W)*675(H)*550(D)mm	42kg	PGH64 x 1	P14x1/P20 (optional)	Boiler x 1	Piston pump x 1
<b>JL22-IN5C</b>	2700W	400(W)*580(H)*550(D)mm	40kg	—	—	Boiler x 1	Piston pump x 1
<b>JL23-ES4C</b>	2700W	400(W)*667(H)*550(D)mm	42kg	Ditting EK7 x 1	P14x1/P20 (optional)	Boiler x 1	Gear pump x 1

Mixer	Screen Type	Spout Height	Drip Tray	Bean Hopper	Instant Canister	Waste Bin
2	10.1" touch screen	80-115mm	1.5L, direct drainage (optional)	1.5kg x 1	1.5L x 3	50 cakes direct slagging off (optional)
3pcs 4pcs(optional)	10.1" touch screen	80-115mm	1.5L, direct drainage (optional)	—	1.5L x 5	—
2	10.1" touch screen	80-115mm	1.5L, direct drainage (optional)	1.5kg x 1	1.5L x 3	50 cakes direct slagging off (optional)



JL24

CQC CE CB

Daily Output:  
**150 cups**

Colors:



Optional Accessory:  
**Base cabinet**

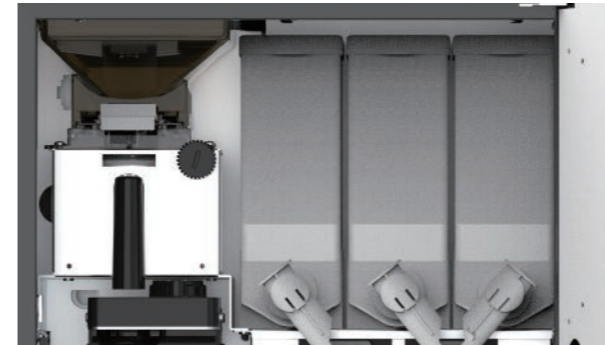

**Large Capacity Design**

The larger mix canister capacity reduces the need for frequent refills, making it ideal for high-usage, space-limited office or commercial environments.



**14-Inch Touchscreen**

The 14-inch touchscreen, combined with an intuitive Android OS, provides easy self-ordering on the front end and seamless equipment management on the back end, enhancing both user experience and operational efficiency.



**Enhanced Performance**

The efficient dehumidification system prevents instant mix from clumping, while the machine's excellent sealing design keeps foreign objects out, ensuring the hygiene and safety of every beverage and guaranteeing premium quality in each cup.

Model	Power	Dimensions	Net Weight	Grinder	Brewer	Heating	Pump
<b>JL24-ES4C</b>	2700W	420(W)*740(H)*535(D)mm	45kg	PGH64 x 1	P14x1/P20 (optional)	Boiler x 1	Piston pump x 1
<b>JL24-IN5C</b>	2700W	420(W)*671(H)*535(D)mm	42kg	—	—	Boiler x 1	Piston pump x 1

Mixer	Screen Type	Spout Height	Drip Tray	Bean Hopper	Instant Canister	Waste Bin
2	14" touch screen	80-120mm	1.5L, direct drainage (optional)	1.5kg x 1	2L x 3	50 cakes direct slagging off (optional)
3pcs 4pcs(optional)	14" touch screen	80-120mm	1.5L, direct drainage (optional)	—	2L x 5	—



# JL18

CQC CE CB

Daily Output:  
**250 cups**

Colors:



Optional Accessory:  
**Base cabinet**



### Precise Grinding

Equipped with the Ditting EMH64 professional grinder, offering precise and efficient grinding, providing solid hardware support for high-quality coffee output and quick cup delivery.



### Premium Coffee Brewer

Featuring the high-performance P14 brewer (optional P20) and a 2700W Storage Boiler, ensuring efficient and stable 9-bar pressure and 92°C optimal extraction for premium coffee quality.



### 14-Inch Vertical Screen

Compact body with a 14-inch vertical screen, offering powerful performance in a small form factor, ideal for various commercial environments.

Model	Power	Dimensions	Net Weight	Grinder	ES Brewer	Filter Brewer	Heating	Pump
<b>JL18-ES3C</b>	2700W	310(W)*713(H)*482(D)mm	40.5kg	Ditting EMH64 x1 Jetinno PGH64 (optional)	P14x1/P20 (optional)	—	Boiler x 1	Gear pump x 1
<b>JL18-BTC3C</b>	2700W	310(W)*713(H)*482(D)mm	40.5kg	Ditting EMH64 x1 Jetinno PGH64 (optional)	—	14g x 1(coffee)	Boiler x 1	Piston pump x 1

Mixer	Screen Type	Hot Water Spout	Drip Tray	Bean Hopper	Instant Canister	Waste Bin
1	14" touch screen	1	1.3L, direct drainage (optional)	1.8kg x 1	3.5L x 1 +2.3L x 1	50 cakes direct slagging off (optional)
1	14" touch screen	1	1.3L, direct drainage (optional)	1.8kg x 1	3.5L x 1 +2.3L x 1	50 cakes direct slagging off (optional)



JL26

CQC CE CB

Daily Output:  
**250 cups**

Colors:  
●

Optional Accessory:  
**Base cabinet**

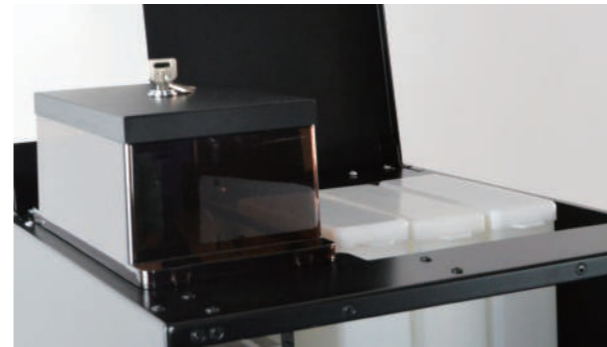

**Efficient Grinding**

Equipped with the Ditting EMH64 professional grinder, ensuring precise and efficient grinding for high-quality coffee output and quick cup delivery.



**Large Capacity Design**

The expanded canister capacity reduces the need for frequent refills, making it ideal for high-usage, space-limited office or commercial environments.



**Multi-Canister Design**

1 bean hopper and 3 instant canisters, capable of preparing over 10 different types of coffee and instant beverages to meet diverse consumer needs.

Model	Power	Dimensions	Net Weight	Grinder	ES Brewer	Filter Brewer	Heating	Pump
<b>JL26-ES4C</b>	2700W	420(W)*808(H)*520(D)mm	50kg	Ditting EMH64 x 1	P14x1/P20 (optional)	—	Boiler x 1	Gear pump x 1
<b>JL26-ESFB4C</b>	2700W	420(W)*808(H)*520(D)mm	50kg	Ditting EMH64 x 1	P14x1/P20 (optional)	14g x 1(tea)	Boiler x 1	Gear pump x 1
<b>JL26-BTC4C</b>	2700W	420(W)*808(H)*520(D)mm	50kg	Ditting EMH64 x 1	—	14g x 1(coffee)	Boiler x 1	Piston pump x 1

Mixer	Screen Type	Hot Water Spout	Drip Tray	Bean Hopper	Instant Canister	Waste Bin
2	14" touch screen	1	1.5L, direct drainage (optional)	1.5kg x 1	2L x 3	80 cakes direct slagging off (optional)
1	14" touch screen	1	1.5L, direct drainage (optional)	1.5kg x 1	2L x 3	80 cakes direct slagging off (optional)
2	14" touch screen	1	1.5L, direct drainage (optional)	1.5kg x 1	2L x 3	80 cakes direct slagging off (optional)





JL50

CQC CE CB

Daily Output:  
**250 cups**

Colors:  
●

Optional Accessory:  
**Base cabinet**

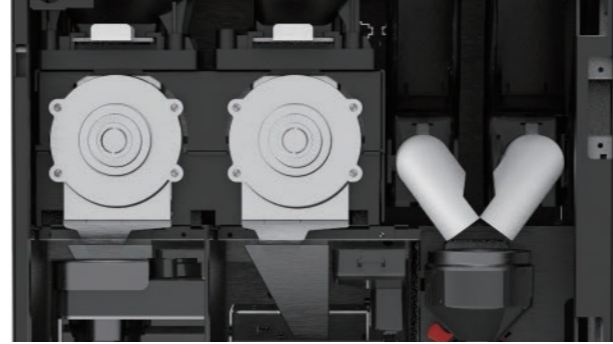

**Dual Grinder and Dual Brewers**

Dual bean hoppers, dual grinders, and dual brewing systems allow for two different coffee beans, enhancing both performance and efficiency.



**Strong and Stable Performance**

Equipped with commercial-grade components, including storage boiler and gear pump, significantly improving efficiency and stability, ensuring fast beverage delivery even during peak hours.



**Diverse Beverage Options**

Featuring dual bean hoppers and 2.3L + 3.5L canisters, capable of preparing over 10 different types of coffee and instant beverages.

Model	Power	Dimensions	Net Weight	Grinder	ES Brewer	Filter Brewer	Heating	Pump
<b>JL50A</b>	2700W	365(W)*750(H)*535(D)mm	60kg	Ditting EMH64 x 2	P14 x2 / P20 (optional)	—	Boiler x 1	Gear pump x 1
<b>JL50B</b>	2700W	365(W)*750(H)*535(D)mm	60kg	Ditting EMH64 x 2	P14 x1 / P20 (optional)	14g x 1(coffee)	Boiler x 1	Gear pump x 1

Mixer	Screen Type	Hot Water Spout	Drip Tray	Bean Hopper	Instant Canister	Waste Bin
1	14" touch screen	1	1L, direct drainage (optional)	5Lx1+2.8Lx1	2.3L x1 +3.5L x1	80 cakes direct slagging off (optional)
1	14" touch screen	1	1L, direct drainage (optional)	5Lx1+2.8Lx1	2.3L x1 +3.5L x1	80 cakes direct slagging off (optional)



Designed for commercial establishments, Ho.Re.Ca Machines feature professional high-efficiency grinding and stable high-pressure extraction, delivering rich and intense espresso flavors. The advanced fresh milk system creates dense, creamy milk foam for a smooth and refined taste. Smart operation supports one-touch brewing, remote management, and auto-cleaning, making it an ideal solution for high-quality coffee service in business settings.



# JL36

CQC CE CB

Daily Output:  
**100 cups**

Colors:  
● ●

Optional Accessory:  
**Fresh Milk Fridge / Base cabinet**



### Stylish Design

Expertly crafted by Italian designers, featuring a 10.1-inch touchscreen, mirror-finish stainless steel front panel, and three-color breathing lights, highlighting its premium feel.



### Smart Auto-Cleaning

Innovative automatic milk system cleaning function with one-touch cleaning and no manual intervention required. The intelligent timed cleaning feature ensures worry-free maintenance.



### Removable Bean Hopper

The bean hopper can be easily removed with one touch, allowing for quick bean changes to cater to different flavor preferences and enhancing user convenience.

Model	Power	Dimensions	Net Weight	Grinder	ES Brewer	Heating	Pump	Milk System
<b>JL36A</b>	3200W	300(W)*585(H)*512(D)mm	22kg	SGH64 x 1	S14x1/S20 (optional)	Thermoblock x 2	Piston pump x 2	Milk frother
<b>JL36B</b>	1700W	300(W)*585(H)*512(D)mm	20kg	SGH64 x 1	S14x1/S20 (optional)	Thermoblock x 1	Piston pump x 1	—

Screen Type	Spout Height	Drip Tray	Bean Hopper	Water Tank	Waste Bin
10.1" touch screen	105-180mm	1.2L, direct drainage (optional)	1200g x 1	2L, Opt. 8L	70 cakes (10g) direct slagging off (optional)
10.1" touch screen	105-180mm	1.2L, direct drainage (optional)	1200g x 1	2L, Opt. 8L	70 cakes (10g) direct slagging off (optional)



JL32

CQC CE CB

Daily Output:  
**200 cups**

Colors:

Optional Accessory:  
**Fresh Milk Fridge / Base cabinet****Dual Pump & Dual Boiler**

Simultaneous coffee and fresh milk preparation, improving beverage production efficiency and reducing wait time for customers.

**Dual Canister Design**

Dual instant canisters supporting over 20 types of coffee and instant beverages to meet diverse consumer needs.

**Effortless Maintenance**

Multi-mode automatic cleaning with an intelligent monitoring system, simplifying maintenance and enhancing operational efficiency.

Model	Power	Dimensions	Net Weight	Grinder	ES Brewer	Heating	Pump	Milk System
<b>JL32A</b>	2900W	350(W)*620(H)*560(D)mm	30kg	PGH64 x 1	P20x1/P14 (optional)	Boiler x 1 Thermoblock x 1	Piston pump x 2	Milk frother
<b>JL32B</b>	2900W	350(W)*620(H)*560(D)mm	29kg	PGH64 x 1	P20x1/P14 (optional)	Boiler x 1 Thermoblock x 1	Piston pump x 2	Milk frother
<b>JL32C</b>	2900W	350(W)*620(H)*560(D)mm	29kg	PGH64 x 1	P20x1/P14 (optional)	Boiler x 1	Piston pump x 1	—

Screen Type	Drip Tray	Bean Hopper	Instant Canister	Water Tank	Waste Bin
10.1" touch screen	0.6L, direct drainage (optional)	1500g x 1	3L x 1 + 2L x 1	4L	40 cakes (8g) direct slagging off (optional)
10.1" touch screen	0.6L, direct drainage (optional)	1500g x 1	—	4L	40 cakes (8g) direct slagging off (optional)
10.1" touch screen	0.6L, direct drainage (optional)	1500g x 1	3L x 1 + 2L x 1	4L	40 cakes (8g) direct slagging off (optional)



JL33

CQC CE CB

Daily Output:  
**200 cups**

Colors:

Optional Accessory:  
**Fresh Milk Fridge / Base cabinet****Dual Bean Hopper & Dual Grinder**

This machine allows for the simultaneous use of two different coffee beans, with two grinding systems operating independently.

**High-Performance Brewing System**

Equipped with the high-performance P14 brewer (optional P20) and a 2700W storage boiler, achieving efficient and stable 9-bar pressure and 92°C optimal extraction for premium coffee quality.

**Three Water Supply Options**

Built-in 4L water tank, with the option to connect to pressurized direct drinking water or bottled water, providing flexibility for various usage scenarios.



Model	Power	Dimensions	Net Weight	Grinder	ES Brewer	Heating	Pump	Milk System
<b>JL33A</b>	2900W	350(W)*628(H)*560(D)mm	33kg	PGH64 x 2	P20x1/P14 (optional)	Boiler x 1 Thermoblock x 1	Piston pump x 2	Milk frother
<b>JL33B</b>	2900W	350(W)*628(H)*560(D)mm	32kg	PGH64 x 2	P20x1/P14 (optional)	Boiler x 1 Thermoblock x 1	Piston pump x 2	Milk frother
<b>JL33C</b>	2900W	350(W)*628(H)*560(D)mm	32kg	PGH64 x 2	P20x1/P14 (optional)	Boiler x 1	Piston pump x 1	—
<b>JL33D</b>	2900W	350(W)*628(H)*560(D)mm	31kg	PGH64 x 2	P20x1/P14 (optional)	Boiler x 1	Piston pump x 1	—

Screen Type	Drip Tray	Bean Hopper	Instant Canister	Water Tank	Waste Bin
10.1" touch screen	0.6L, direct drainage (optional)	1000g x 2	2L x 1 + 1.5L x 1	4L	40 cakes (8g) direct slagging off (optional)
10.1" touch screen	0.6L, direct drainage (optional)	1000g x 2	—	4L	40 cakes (8g) direct slagging off (optional)
10.1" touch screen	0.6L, direct drainage (optional)	1000g x 2	2L x 1 + 1.5L x 1	4L	40 cakes (8g) direct slagging off (optional)
10.1" touch screen	0.6L, direct drainage (optional)	1000g x 2	—	4L	40 cakes (8g) direct slagging off (optional)



JL35

CQC CE CB

Daily Output:  
**250 cups**

Colors:



Optional Accessory:  
**Fresh Milk Fridge / Base cabinet**



**Dual Grinding & Brewing System**

Dual bean hoppers paired with the high-performance Ditting EMH64 dual grinder and P14/P20 premium brewers, meeting diverse coffee flavor demands with exceptional performance.



**Hot & Cold Milk Frothing**

Featuring the Italian Fluid-o-tech milk pump, which precisely controls the temperature and humidity of the milk foam, producing fine, smooth hot and cold milk foam to enhance the flavor and quality of fresh milk coffee.



**Diverse Beverage Flavors**

Two large-capacity mix canisters and six syrup lines offering the flexibility to create a wide variety of flavored drinks, satisfying diverse consumer preferences.

Model	Power	Dimensions	Net Weight	Grinder	ES Brewer	Heating	Pump	Milk System
<b>JL35A</b>	3100W	365(W)*730(H)*535(D)mm	66kg	Ditting EMH64 x 2	P14x2/P20 (optional)	Boiler x 2	Gear pump x 1	Milk pump
<b>JL35B</b>	3100W	365(W)*730(H)*535(D)mm	58kg	Ditting EMH64 x 1	P14x1/P20 (optional)	Boiler x 2	Gear pump x 1	Milk pump

Screen Type	Mixer	Bean Hopper	Instant Canister	Syrup	Drip Tray	Waste Bin
14" touch screen	1	5Lx 1+2.8Lx 1	2.3L x 1 +3.5L x 1	Optional 6 groups	1L, direct drainage (optional)	80 cakes direct slagging off (optional)
14" touch screen	2	5Lx 1	2.3L x 1 +3.5L x 2	Optional 6 groups	1L, direct drainage (optional)	80 cakes direct slagging off (optional)



# Vending

Delivering exceptional coffee flavor and a diverse selection of beverages. Equipped with an intelligent self-service system, it features automatic cup dispensing, remote management, and multiple payment options. Designed for efficiency and personalization, it redefines modern beverage consumption.



# JL28

CQC CE CB

Daily Output:  
**200 cups**

Colors:  
● ●

Optional Accessory:  
**Base cabinet**



# JL40

CQC CE CB

Daily Output:  
**200 cups**

Colors:  
●

Optional Accessory:  
**Base cabinet**

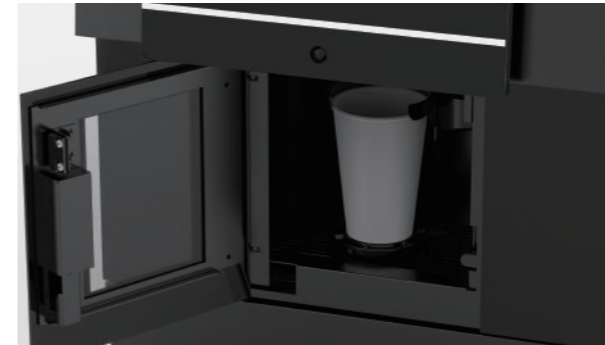

### Built-in Cup Dispenser

Stores up to 75 cups, with an intelligent automatic cup dispensing system, eliminating the need for manual cup retrieval. This saves time and reduces potential contamination.



### Multi-Canister Design

Equipped with four instant canisters, capable of preparing over 10 types of coffee and instant beverages, including classic coffee, milk-based drinks, and juice—perfect for catering to diverse taste preferences.



### Exceptional Performance & Stability

Features a 2700W high-efficiency storage boiler, combined with a precision gear pump to ensure stable temperature and pressure output. Its strong refilling capability meets high-demand usage, providing a seamless and reliable experience.



Model	Power	Dimensions	Net Weight	Grinder	ES Brewer	Heating	Pump
<b>JL28</b>	2700W	420(W)*800(H)*660(D)mm	60kg	PGH64 x 1	P14x1/P20 (optional)	Boiler x 1	Gear pump x 1
<b>JL40</b>	2800W	420(W)*805(H)*650(D)mm	60kg	PGH64 x 1	P20x1/P14 (optional)	Boiler x 1	Gear pump x 1

Cup Delivery Door	Cup Number	Bean Hopper	Instant Canister	Drip Tray	Waste Bin
Manual cup delivery door	75	1.5kg x 1	2L x 2+ 1.5L x 2	1.5L, direct drainage (optional)	130 cakes direct slagging off (optional)
Manual cup delivery door	75	1.5kg x 1	3L x 2+ 2L x 2	1.5L, direct drainage (optional)	130 cakes direct slagging off (optional)





# JL220

CQC CE CB

Daily Output:  
**200 cups**

Colors:  
●

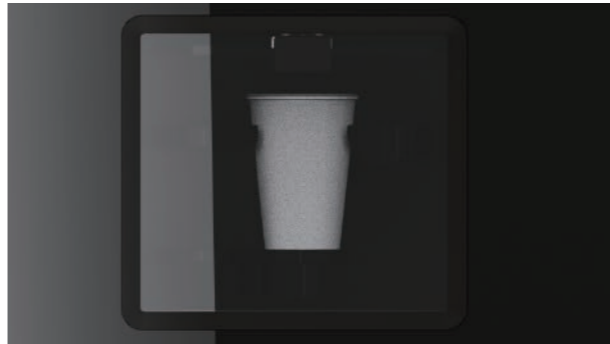

### Compact Design with Smart Features

Equipped with a 14-inch vertical screen and PIR motion-sensing technology for an intuitive and smart user experience. With a footprint of just 0.35m<sup>2</sup>, it is ideal for compact office or commercial spaces.



### Diverse Beverage Options

Features 1 bean hopper and 5 instant mix canisters, offering 20+ beverage choices to cater to various taste preferences.



### Effortless Maintenance

Multiple automatic cleaning options, advanced intelligent detection, and IoT backend management simplify maintenance, allowing for a hassle-free and efficient operation.

Model	Power	Dimensions	Net Weight	Grinder	ES Brewer	Heating	Pump
<b>JL220</b>	2900W	500(W)*1675(H)*700(D)mm	100kg	PGH64 x 1	P20x1/P14 (optional)	Boiler x 1	Piston pump x 1

Cup Delivery Door	Cup Number	Lid Number	Cup Specifications	Bean Hopper	Instant Canister	Drip Tray	Waste Bin
Cup Delivery Door	120	90	D80mm, 10 Oz	1.8kg x1	4L x 2+ 2L x 3	15L	130 cakes



# JL300

CQC CE CB

Daily Output:  
**150 cups**

Colors:  
● ●

Optional Accessory:  
**BIB / Top Light Box**



**Built-in Cup Dispenser**

Stores up to 150 cups with an intelligent automatic cup dispensing system, enabling a fully self-service experience. From bean to cup, enjoy fresh coffee with just one touch.



**Immersive Self-Service Experience**

Transparent bean hopper design provides a clear view of the grinding process. Features automatic cup dispensing, automatic lift door, manual lid retrieval, and a packaging shelf, enhancing the overall coffee purchase experience.



**Powerful Backend Management**

Integrated with the advanced SaaS coffee machine management platform, supporting remote bulk operations and management of coffee machines. Enables real-time monitoring and data analysis, optimizing operations and ensuring full control over each machine's performance.

Model	Power	Dimensions	Net Weight	Grinder	ES Brewer	Filter Brewer	Heating	Pump
<b>JL300-ES7C</b>	2800W	664(W)*1855(H)*720(D)mm	150kg	PGH64 x 1	P14x1/P20 (optional)	—	Boiler x 1	Piston pump x 1
<b>JL300-ESFB7C</b>	2800W	664(W)*1855(H)*720(D)mm	150kg	PGH64 x 1	P14x1/P20 (optional)	14g x 1(tea)	Boiler x 1	Piston pump x 1
<b>JL300-IN8C</b>	2800W	664(W)*1855(H)*720(D)mm	150kg	—	—	—	Boiler x 1	Piston pump x 1

Cup Delivery Door	Cup Number	Lid Number	Cup Specifications	Bean Hopper	Instant Canister	Drip Tray	Waste Bin
Cup Delivery Door	150	85	D90mm, 12 Oz 16 Oz(optional)	1.8kg x1	4L x 6	20L	140 cakes
Cup Delivery Door	150	85	D90mm, 12 Oz 16 Oz(optional)	1.8kg x1	4L x 6	20L	140 cakes
Cup Delivery Door	150	85	D90mm, 12 Oz 16 Oz(optional)	—	4L x 8	20L	—



# JL500

CQC CE CB

Daily Output:  
**250 cups**

Colors:  
●

Optional Accessory:  
**BIB / Top Light Box**



### High-Performance Brewing System

Equipped with a high-performance P14 brewer (optional P20) and a 2700W storage boiler, ensuring efficient and stable 9-bar pressure and 92°C optimal extraction for premium coffee quality.



### 20+ Hot & Cold Beverage Options

Features a multi-canister design with a built-in chiller, capable of preparing over 20 types of hot and cold coffee and instant beverages.



### 27-Inch Touchscreen

Sleek and modern design with an intuitive 27-inch touchscreen for effortless operation provides a seamless and convenient coffee experience.

Model	Power	Dimensions	Net Weight	Grinder	ES Brewer	Filter Brewer	Heating	Pump
<b>JL500-ES7C-PI</b>	2700W	664(W)*1855(H)*720(D)mm	150kg	Ditting EMH64 x1	P14x1/P20 (optional)	—	Boiler x 1	Gear pump x 1
<b>JL500-ESFB7C-PI</b>	2700W	664(W)*1855(H)*720(D)mm	150kg	Ditting EMH64 x1	P14x1/P20 (optional)	14g x 1(tea)	Boiler x 1	Gear pump x 1
<b>JL500-IN8C-PI</b>	2700W	664(W)*1855(H)*720(D)mm	150kg	—	—	—	Boiler x 1	Piston pump x 1

Cup Delivery Door	Cup Number	Lid Number	Cup Specifications	Bean Hopper	Instant Canister	Drip Tray	Waste Bin
Manual cup delivery door	150-200	130 (90mm) optional	D80mm, 10Oz 90mm, 12Oz(optional)	1.5kg x 1	4L x 6	15L	125 cakes
Manual cup delivery door	150-200	130 (90mm) optional	D80mm, 10Oz 90mm, 12Oz(optional)	1.5kg x 1	4L x 6	15L	125 cakes
Manual cup delivery door	150-200	130 (90mm) optional	D80mm, 10Oz 90mm, 12Oz(optional)	—	4L x 8	15L	—



# JL550

CQC CE CB

Daily Output:  
**250 cups**

Colors:  
●

Optional Accessory:  
**BIB / Top Light Box**



### Ditting Grinder

Features the Swiss Ditting EK7 grinder with 64mm flat burrs for even grinding. Made of impact-resistant special steel, it offers multi-stage grind size adjustment to meet various brewing needs.



### Built-in Ice Maker

Equipped with powerful compressor and evaporator, this integrated system combines ice production and chilled water functions. With precise ice output control and a 1.5kg ice storage capacity, it ensures a continuous supply of ice for high-demand scenarios.



### 40 Hot & Cold Beverage Options

Featuring a multi-canister design with the option for a tea brewing function, capable of producing over 40 types of hot and cold beverages, providing a one-stop beverage solution with a diverse selection to meet varying taste preferences.

Model	Power	Dimensions	Net Weight	Grinder	ES Brewer	Filter Brewer	Heating	Pump
<b>JL550-ES7C-PI</b>	2800W	1000(W)*1855(H)*785(D)mm	280kg	Ditting EK7 x 1	P14x1/P20 (optional)	—	Boiler x 1	Gear pump x 1
<b>JL550-ESFB7C-PI</b>	2800W	1000(W)*1855(H)*785(D)mm	280kg	Ditting EK7 x 1	P14x1/P20 (optional)	14g x 1(tea)	Boiler x 1	Gear pump x 1

Cup Delivery Door	Cup Number	Lid Number	Cup Specifications	Bean Hopper	Instant Canister	Drip Tray	Waste Bin
Cup Delivery Door	150	130	D90mm, 12 Oz 16 Oz(optional)	1.5kg x 1	4L x 6	15L direct drainage (optional)	125 cakes
Cup Delivery Door	150	130	D90mm, 12 Oz 16 Oz(optional)	1.5kg x 1	4L x 6	15L direct drainage (optional)	125 cakes



Enjoy a seamless self-service experience with diverse coffee flavors. Automatic cup dispensing and lid sealing ensure a touch-free, grab-and-go convenience. Smart management and remote operation make high-quality coffee service effortless and efficient.



# JL510

CQC CE CB

Daily Output:  
**250 cups**

Colors:



Optional Accessory:  
**BIB / Top Light Box**

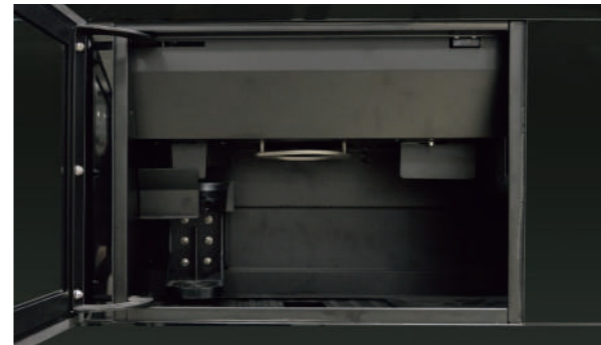

### Automatic Cup Dispensing & Lid Capping

Automatic cup dispensing and lid capping, with smart alerts for low cups/lids and missing cups/lids, improving operational speed and efficiency.



### Automatic Timed Cleaning

Allows for scheduled automatic cleaning of the entire machine or specific components, reducing the risk of residue in the system and enhancing beverage hygiene and safety.



### Remote Cloud Monitoring

Enables real-time monitoring of equipment status via mobile or computer, including instant mix levels, beverage sales, and troubleshooting, eliminating the need for on-site staff.

Model	Power	Dimensions	Net Weight	Grinder	ES Brewer	Filter Brewer	Heating	Pump
<b>JL510-ES7C-PI-Y</b>	2700W	664(W)*1855(H)*720(D)mm	150kg	Ditting EMH64 x1	P14x1/P20 (optional)	—	Boiler x 1	Gear pump x 1
<b>JL510-ESFB7C-PI-Y</b>	2700W	664(W)*1855(H)*720(D)mm	150kg	Ditting EMH64 x1	P14x1/P20 (optional)	14g x 1(tea)	Boiler x 1	Gear pump x 1
<b>JL510-IN8C-PI-Y</b>	2700W	664(W)*1855(H)*720(D)mm	150kg	—	—	—	Boiler x 1	Piston pump x 1

Cup Delivery Door	Cup Number	Lid Number	Cup Specifications	Bean Hopper	Instant Canister	Drip Tray	Waste Bin
Manual cup delivery door	150	130	D90mm, 16 Oz	1.5kg x 1	4L x 6	15L	125 cakes
Manual cup delivery door	150	130	D90mm, 16 Oz	1.5kg x 1	4L x 6	15L	125 cakes
Manual cup delivery door	150	130	D90mm, 16 Oz	—	4L x 8	15L	—



JL560

CQC CE CB

Daily Output:  
**250 cups**

Colors:



Optional Accessory:  
**BIB / Top Light Box**

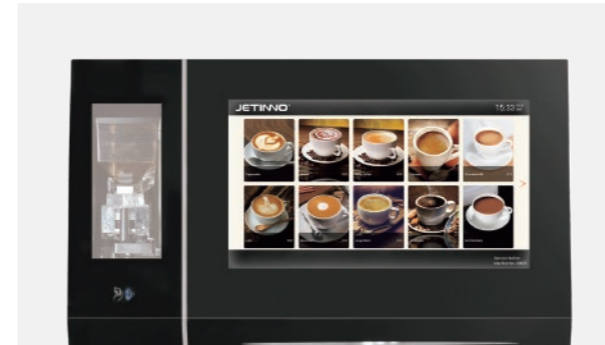

**Grab & Go Contactless Experience**

One-touch activation for automatic cup dispensing, cup placement, lid capping, and automatic lift door—fully automated operation, providing a completely contactless beverage experience.



**Standardized Ice Beverage Output**

Precise control over ice output and continuous ice production, ensuring each cup of iced coffee meets consistent standards and can handle high-volume demand during peak hours.



**Visible Freshly Ground Coffee**

The transparent glass panel in front of the coffee bean hopper and grinder allow customers to see the coffee beans being freshly ground, enhancing the sensory experience as they enjoy the rich aroma of every cup.

Model	Power	Dimensions	Net Weight	Grinder	ES Brewer	Filter Brewer	Heating	Pump
<b>JL560-ES7C-PI-Y</b>	2800W	1000(W)*1855(H)*785(D)mm	280kg	Ditting EK7 x 1	P14x1/P20 (optional)	—	Boiler x 1	Gear pump x 1
<b>JL560-ESFB7C-PI-Y</b>	2800W	1000(W)*1855(H)*785(D)mm	280kg	Ditting EK7 x 1	P14x1/P20 (optional)	14g x 1(tea)	Boiler x 1	Gear pump x 1

Cup Delivery Door	Cup Number	Lid Number	Cup Specifications	Bean Hopper	Instant Canister	Drip Tray	Waste Bin
Cup Delivery Door	150	130	D90mm, 16 Oz	1.5kg x 1	4L x 6	15L direct drainage (optional)	125 cakes
Cup Delivery Door	150	130	D90mm, 16 Oz	1.5kg x 1	4L x 6	15L direct drainage (optional)	125 cakes



JL852

CQC CE CB

Daily Output:  
**300 cups**

Colors:



Optional Accessory:  
**BIB / Top Light Box**



**Integrated Ice and Chilled Water System**

Powerful ice making and storage capabilities, combined with instant cold water dispensing, ensuring efficient preparation of iced and chilled beverages.



**Triple Boiler & Dual Pump System**

Enhances both coffee extraction and milk frothing efficiency, while also improving the quality of fresh milk coffee. The dual systems work simultaneously to reduce customer wait time.



**Smart Hot & Cold Fresh Milk Frothing**

Professional milk pumps provide the foundation for producing thick, smooth hot and cold milk foam, supporting three different types of fresh milk to meet diverse consumer preferences.



**Flavor Syrup Module**

Supports 6 different syrup flavors, unlocking the potential for flavored coffee options. The intelligent syrup dispensing system allows for precise control of sweetness levels, satisfying a variety of taste preferences.

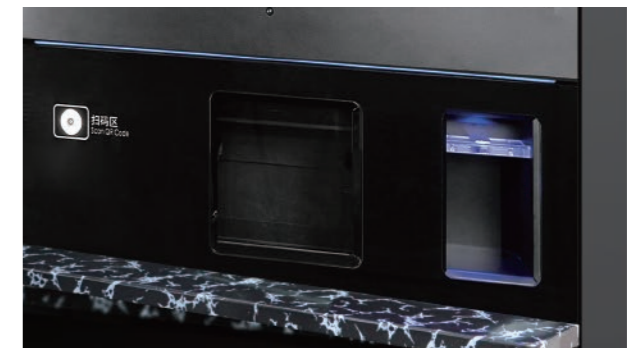

Model	Power	Dimensions	Net Weight	Grinder	ES Brewer	Filter Brewer	Heating	Pump
JL852-ESFB7C6S-FM-Y	3800W	1000(W)*1900(H)*1000(D)mm	450kg	Ditting EMH64 x1 PGH64 (optional)	P14x1/P20 (optional)	14g x 1(tea)	Boiler x 3	Vane pump x 1

Cup Delivery Door	Cup Number	Lid Number	Cup Size	Bean Hopper	Instant Canister	Drip Tray	Waste Bin
Cup Delivery Door	150	130	D90mm, 16 Oz, Opt. 12 Oz	1.8kg x1	4L x 6	20L direct drainage (optional)	125 cakes



## ACCESSORIES



### MC6D Milk Fridge

Voltage/Frequency: 220~240V 50/60Hz  
Power: 48W  
Temperature Range: 0~4°C  
Refrigerant: R600a/10.5g  
Milk Box Capacity: 3.8L  
Effective Volume: 6L  
External Dimensions: 220(W)\*402(H)\*400(D)mm  
Internal Dimensions: 150(W)\*153(H)\*286(D)mm  
Weight: 12kg  
Milk Position Alert: Yes



### BR9CN Professional Milk Fridge

Voltage/Frequency: 220~240V 50/60Hz  
Power: 60W  
Temperature Range: 0~4°C  
Refrigerant: R600a/12g  
Milk Box Capacity: 4.5L  
Effective Volume: 8L  
External Dimensions: 220(W)\*456(H)\*452(D)mm  
Internal Dimensions: 160(W)\*190(H)\*280(D)mm  
Weight: 14.1kg  
Milk Position Alert: -



### Brewing System Cleaning Tablets

Usage: For cleaning coffee machine brewers  
Net Content: 2g per tablet, 100 tablets per bottle



### Milk System Cleaning Tablets

Usage: For cleaning the milk system  
Ratio: 1 tablet mixed with 500ml of water  
Net Content: 4g per tablet, 120 tablets per bottle



### Milk Tank

Capacity: 500ml  
Height: 170mm  
Diameter: 85mm  
Weight: 159.4g



### Milk Tank (Stainless Steel)

Capacity: 600ml  
Height: 220mm  
Diameter: 95mm  
Weight: 521.9g